

Monitor Setup Guide

The right monitors.
The correct setup.
Proper sound.



GENELEC®

Table of contents

Genelec Key Technologies	3
What is a monitor?	4
What is a reference monitor?	4
Selecting the correct monitors	4
Identifying your listening area	5
Monitor and listening location placement in a room	8
Back wall cancellation	9
Calibration	13
Acoustic treatments	16
Room acoustics improvements	18
Listening distance and Sound Pressure Level	20
Direct Sound Dominance	21
Product performance	22
Sound basics	22
Sound radiation	23
Radiation space	24
Cancellation because of a wall behind the monitor	25
Genelec G • Stencil tool	26
Test signals	27

Genelec Key Technologies

For over 35 years Genelec has been guided by a single idea – to make perfect active monitors that deliver neutral and accurate sound in every kind of acoustical environment. In our quest to improve all aspects of monitoring quality we continuously develop innovative solutions in driver technologies, electronic circuitry, signal processing, enclosure designs, and materials. Learn more about our key technologies on our website at www.genelec.com.



Active Crossover

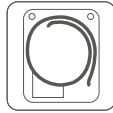

LSE™ Laminar Spiral Enclosure™

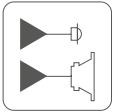

Dedicated Amplifiers



Versatile Mounting



Protection Circuitry

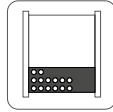

Bass Management

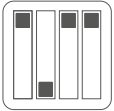

Room Response



ISS™ Intelligent Signal Sensing™



DCW™ Directivity Control Waveguide™

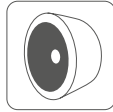

MDC™ Minimum Diffraction Coaxial™



MDE™ Minimum Diffraction Enclosure™

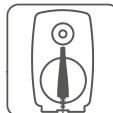

SAM™ Smart Active Monitors™



Iso-Pod™ Stand

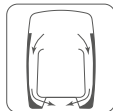

LIP™ Laminar Integrated Port™



Reflex Port



NCE™ Natural Composite Enclosure™

What is a monitor?

A monitor, by definition, observes, checks, controls, warns or keeps continuous record of something. An audio monitor is more than a good-sounding loudspeaker. It is a device used in the process of recording, mixing or broadcasting audio in any environment where accurate listening is needed. A monitor is a professional tool.



What is a reference monitor?

A reference monitor shall reveal the truth about the program being monitored. It shall not add anything to nor remove or mask anything contained in the program. Such a monitor should be set up in an optimal position in the room with minimized influences from its environment. What we hear is the combination of our listening ability, the monitor's performance and the room acoustic.

Selecting the correct monitors

Genelec recommends monitors based on typical listening distances and sound pressure levels. A matching subwoofer exists for every monitor. Refer to our online selection tools or ask your local dealer or distributor for detailed advice. Here are some tips to define your listening distance and identify your optimal listening area.

Identifying your listening area

Divide your room into three equal-sized areas; front, centre and rear.

For music productions place your listening setup in the front area. The angle between the left and right monitors should be 60° degrees. Each monitor should be aimed towards the listening position. For film production, place your listening setup in the rear area.

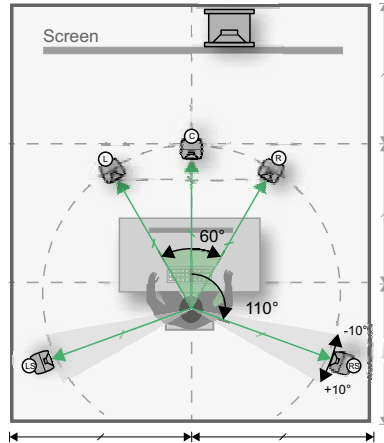
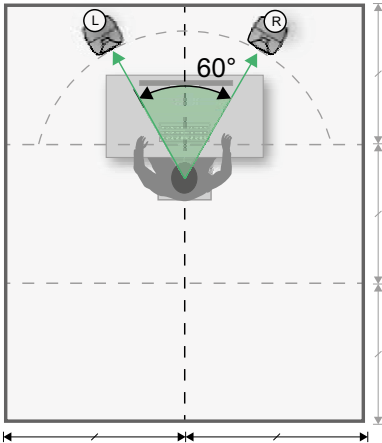

Room resonances between room surfaces are called standing waves or room modes. In the case of resonances, sound pressure maxima occur on the surface. Place the listening position at least one metre from the walls to avoid the zone of the pressure maximum.

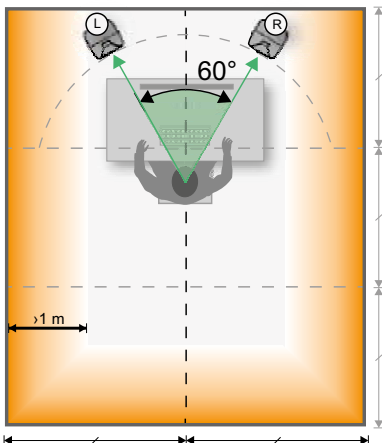

Find the left-right symmetry axis of your room. Place the listening setup symmetrically in the left-right direction.

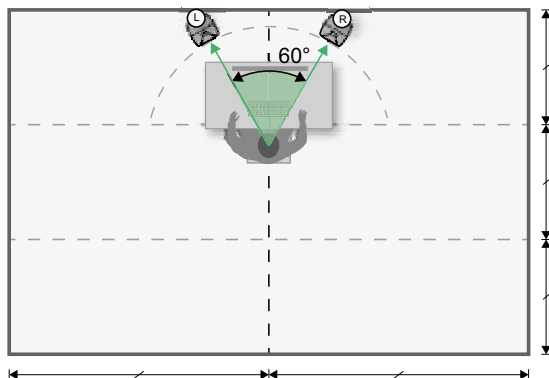

For typical two-way systems, the recommended height of the monitor acoustical axis is at the ear level, usually between 1.2 and 1.4 metres from the floor. Placing the monitors higher with a slight tilt will minimise floor reflections. For standard stereo and multichannel reproduction, do not lift the monitors so high that more than 15 degrees of tilt is required. Monitors should always be aimed towards the listening position. The higher the monitor is from the floor, the lower is the reflection induced frequency response irregularities. However, half room height placement should be avoided, as at low frequencies the ceiling is typically also a reflective surface.

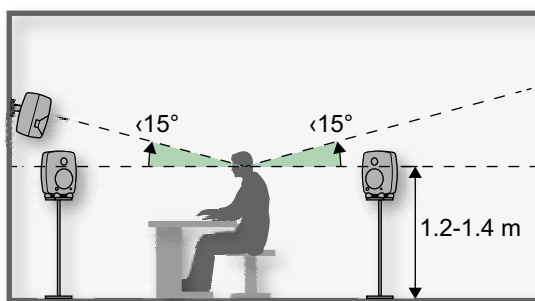

Monitor height (ITU-R BS.775-2 Recommendation)

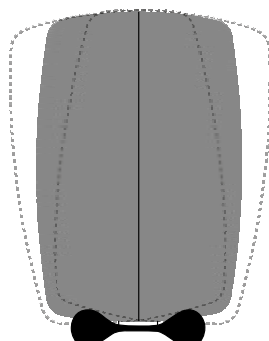

Iso-Pod tilting

Placement suggestions for a 5.1 monitoring setup in two different basic room layouts:

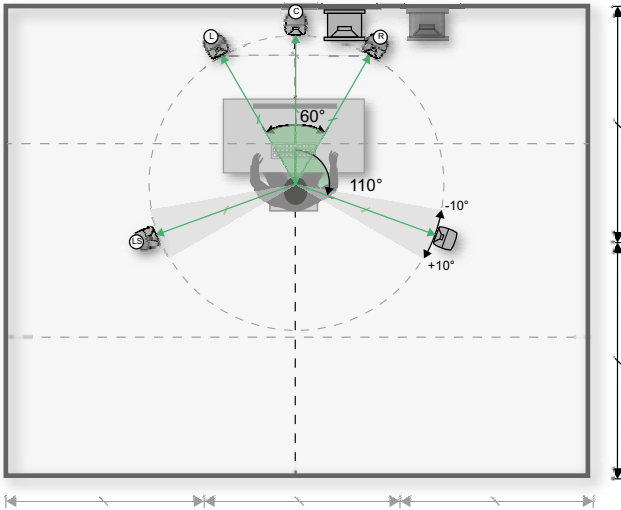
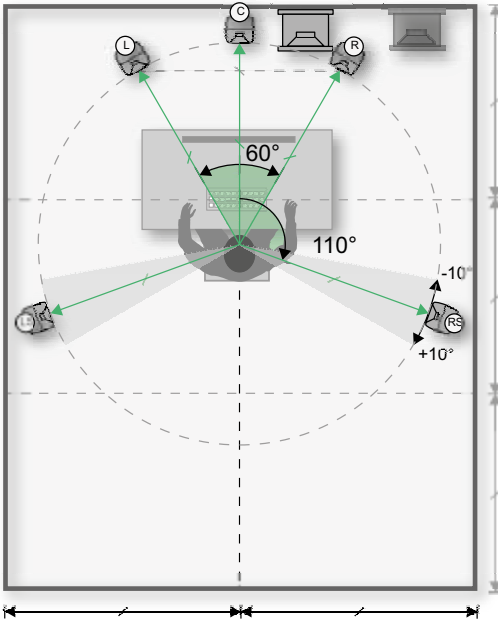

Monitor and listening location placement in a room

Sound is reflected by the walls, ceiling and floor. The sound level at the listener increases when reflected sound is in phase with the direct sound. The sound level decreases when the reflected sound is out of phase with the direct sound.

If the room surfaces have not been designed to diffract the sound energy, most of the reflected sound energy leaves the reflecting wall in the same angle as it arrived to the wall. Avoid placing the monitors so that the immediate side wall, ceiling, and floor reflections travel towards the listening position.

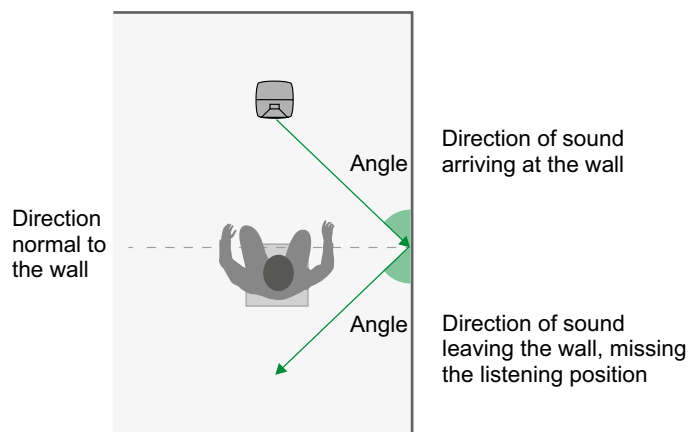

When room dimensions agree with the sound wavelength, sound energy accumulates to form resonances. This resonance sound forms standing waves in the room, with sound pressure maximums and minimums at certain locations in the room depending on the resonance frequency. Location of the monitor in the room affects how much the room mode resonances collect energy and how audible they become. Moving the monitor locations may help to reduce the levels of problematic room mode resonances.

The listening location may be unfavourably situated relative to the room mode resonances. If the listening location is at the location of a null for some mode resonances, the level of those resonances frequencies becomes very low and

these frequencies appear to be missing. Moving the listening location can solve the problem. Typically the listening location is moved forward or backward.

The most accurate stereo imaging can be achieved when the reflections are similar for the left and the right monitor in a stereo pair. This can be achieved by maintaining the same distance to the nearest side wall and the wall behind the monitor, placing the left and right monitors to the same height in the room, and placing the listening location symmetrically in the room in the left-right direction.

Back wall cancellation

Monitor placement

To avoid cancellation of audio because of the sound reflecting back from the wall behind the monitor, follow the placement guideline below. This reflection happens at relative low woofer frequencies only. Avoiding the cancellation is important because the reflected sound can reduce the woofer output causing the monitor low frequency output to appear to be too low. To avoid the cancellation, push the monitor close enough to the wall. Typically the distance of the monitor front to the wall should be less than 0.6 meters. This ensures that the low frequency output is not reduced. The monitor needs a minimum clearance of 0.05 m to the wall to ensure full output from the rear bass reflex port.

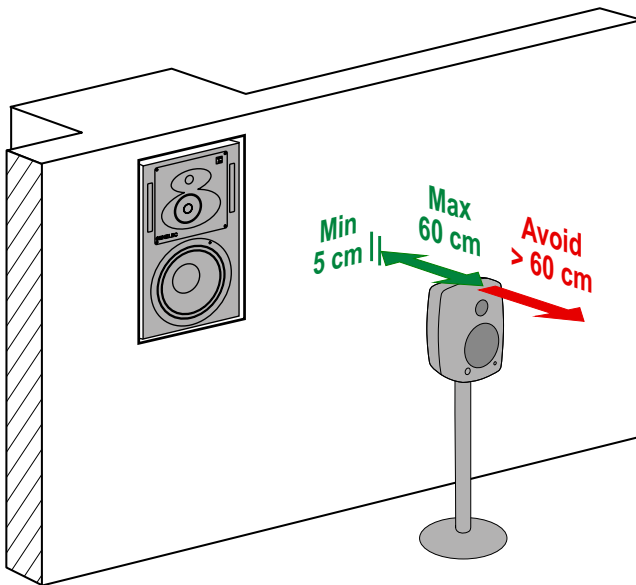

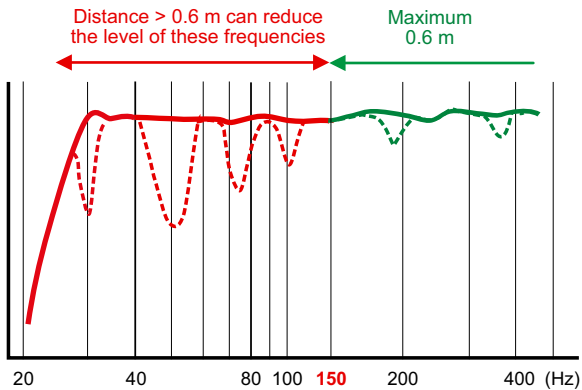

Placement of monitors and subwoofer

At low frequencies, it is crucial that the most fundamental room modes are equally excited. Using a single subwoofer, a placement along the front wall, slightly off-centre from the room middle axis could be recommended. Using two or four subwoofers around the room may be a good solution to even out room mode excitations.

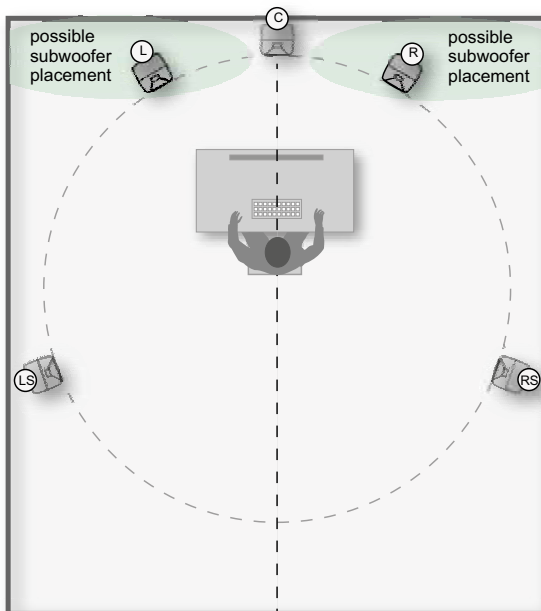

Placing a subwoofer at a wall or in a corner produces the highest low frequency output. At low frequencies, the flattest response can be achieved when the room mode resonances are equally excited. A single subwoofer is usually placed along the front wall, slightly off-centre from the room's middle axis. Two subwoofers may be a good solution to produce an even flatter response. Note that during level calibration, the subwoofer output level is set at the same level than the main monitor system.

Genelec active 7000 series subwoofers have a crossover filter set to 85 Hz. The subwoofer reproduces the frequencies lower than 85 Hz. Higher frequencies are reproduced by the monitors.

Genelec Smart Active Monitoring (SAM) subwoofers enable selection of the crossover frequency between 50 and 100 Hz. Set the subwoofer crossover to a frequency where both the monitors and the subwoofer output sound.

Adjust the subwoofer phase at the crossover. Reduction of sound level may occur at the crossover frequency if the phase is not aligned. The phase alignment is described in the subwoofer operating manual.

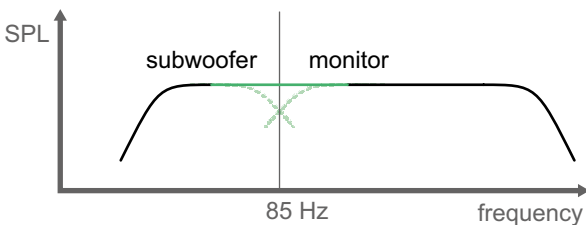

The cut-off frequency for the low frequency effect (LFE) channel can be selected separately as 85 Hz or 120 Hz. In certain subwoofers, the LFE content above 85 Hz may be redirected to the centre monitor, allowing full range LFE channel monitoring.

Typical recommended distances from the wall behind monitors and subwoofer are shown in the picture overleaf.

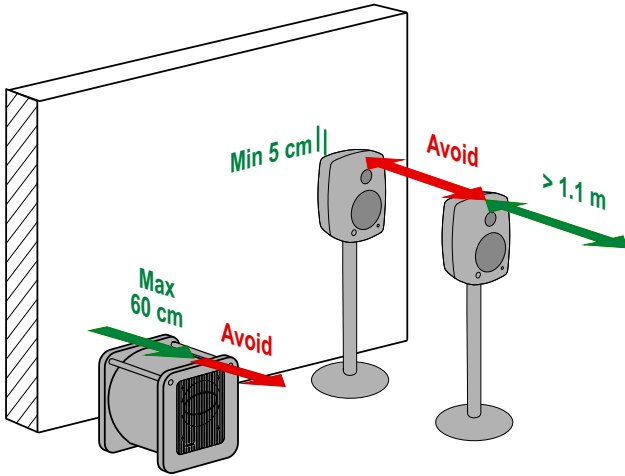

Post-production facility applications

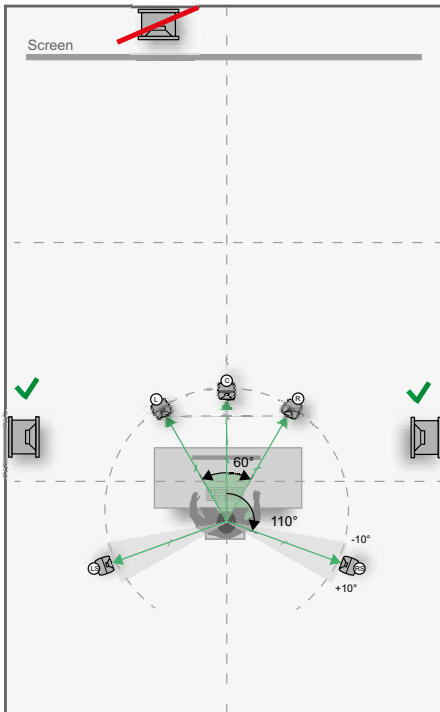

In certain applications, such as large post-production studios, subwoofer placement along the front wall is not recommended as this places the subwoofer very far from the listening position, and the subwoofer frequency response will not be flat. In these cases, we recommended locating the subwoofer close to the main monitor setup along the side walls. Using two subwoofers, one along each side wall, may provide an improved low frequency flatness.

Calibration

The acoustic environment has a major influence on the sound quality. Walls, ceiling, and floor as well as large objects like mixing consoles, tables, equipment racks, and furniture cause reflections. Acoustic calibration minimizes room influences and retrieves flat and neutral frequency response.

Example of compromised listening condition: excessive bass level in the monitoring room may result in a lack of bass in the final mix.

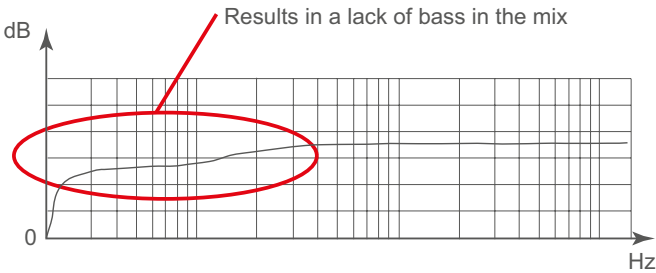
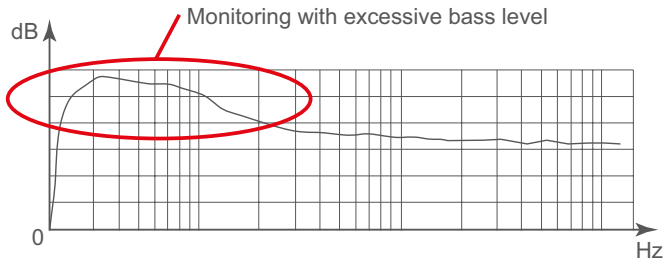

All Genelec active monitoring systems have room response adjustments to compensate for room influences and retrieve a flat frequency response at the listening position. Analogue systems feature DIP switch tone controls while Smart Active Monitor (SAM) systems with digital signal processing can calibrate automatically with Genelec AutoCal.

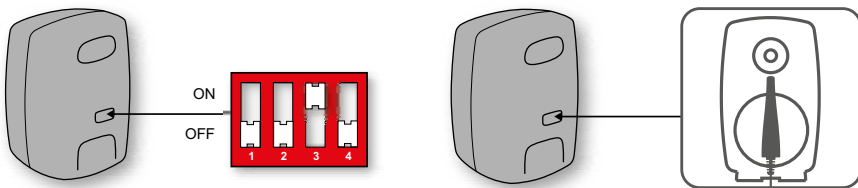

First set the measurement microphone at the ear height in the listening position (typical height: 1.2 to 1.4 m). Ensure that monitors are at correct distances and heights. Take a frequency response measurement. Analyse the measurement results and adjust tone control DIP switches to retrieve a flat and balanced frequency response for each monitor.

For level calibration, first set the rotary input sensitivity control on all monitors fully clockwise. Then, adjust each level control so that all monitors produce the same sound level at the listening position.

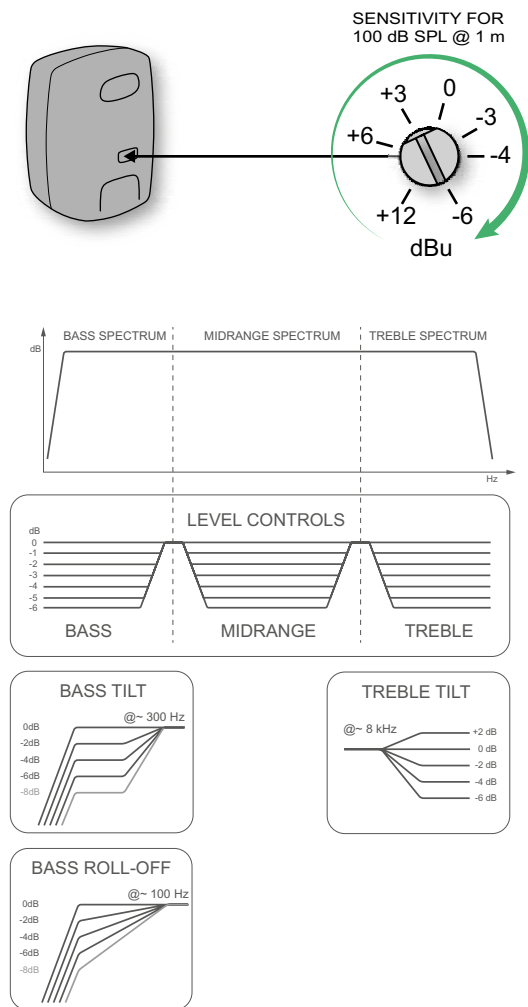

In the example below, the bass tilt control has been used to compensate for a low frequency boost caused by a monitor close to a large wall.

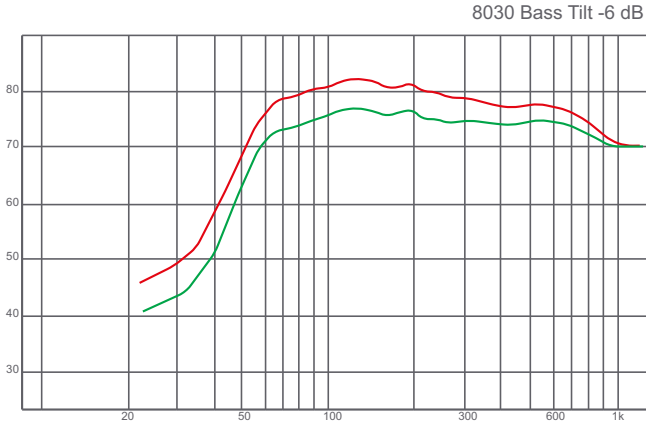

To achieve optimal sound reproduction we recommend to place two-way monitors vertically. When a two-way monitor is placed horizontally, difference in the tweeter and woofer distances will cause reduction of sound level at the crossover frequency when the listener moves sideways from the acoustical axis.

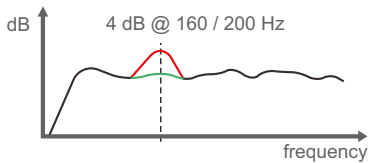
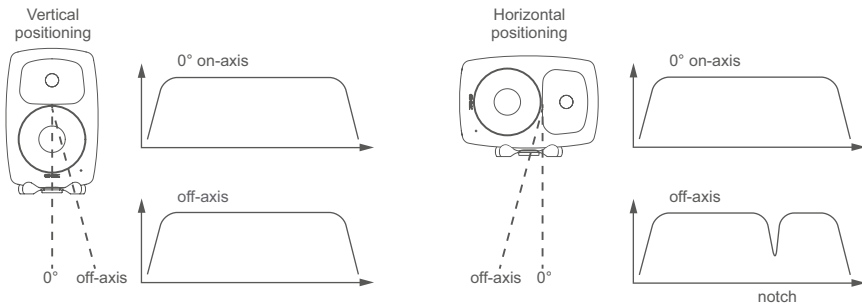

Large table or mixing console in front of the monitors may cause a boost around 160-200 Hz. Some Genelec monitors have a desktop control DIP switch compensating for this boost. SAM systems' AutoCal will compensate for this effect automatically.

Acoustic treatments

Monitor calibration alone helps but may not be sufficient to resolve room acoustic problems.

Audio production rooms are designed for monitoring and should receive adequate acoustic treatments to allow quality monitoring. Several room acoustic improvements are suggested here. However, using services of a professional consultant is highly recommended.

Wall surfaces, ceilings and floors can be reflective, diffusive or absorptive. Combinations of these are often used.

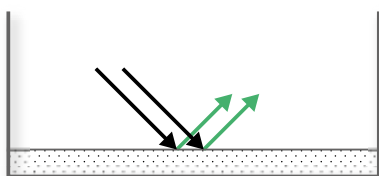

Hard surfaces such as glass, concrete, dry wall or MDF reflect sound.

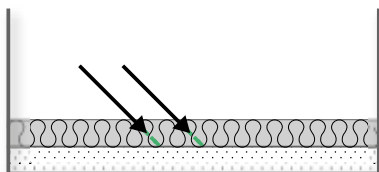

Soft materials such as rock/mineral wool, sofas, heavy curtains or thick carpets absorb sound energy. Thick layer of porous materials are needed to absorb lower frequencies.

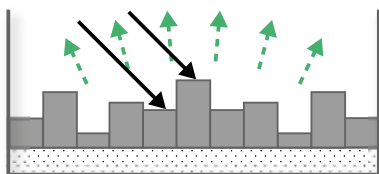

Irregular surfaces scatter sound waves. Spreading angle depends on the diffuser design. Diffusion is usually not effective at low frequencies.

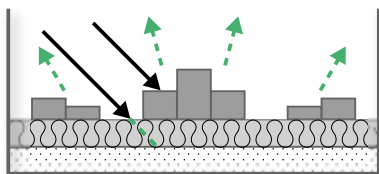

A combination of diffusive and absorptive surfaces can be very effective in reducing the audibility of reflections.

First order reflections can have high level while subsequent reflections become smaller. Control room design minimizes the first order reflection level reaching the listening area. Reflections arriving very soon after the direct sound from the monitor are called early reflections. One aim of control room design is to reduce or eliminate early reflections, having mainly the direct sound from the monitors reaching the listening area.

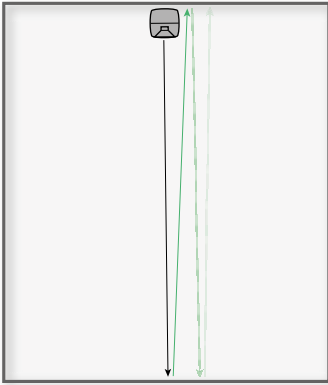

Flutter echo

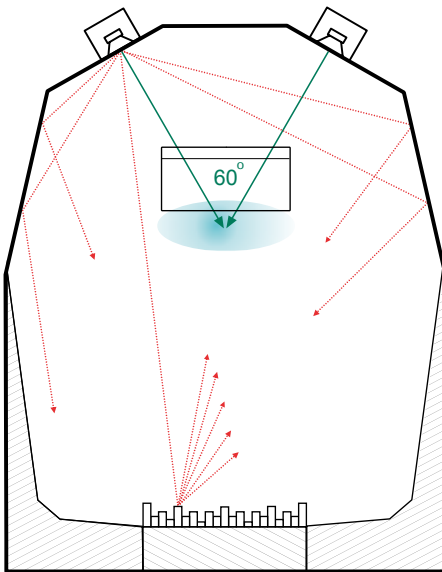

Reflection-free zone around the listening area

Room acoustics improvements

Several acoustic improvements can be made in a typical rectangular room where an audio monitoring setup is installed. Here are a few suggestions.

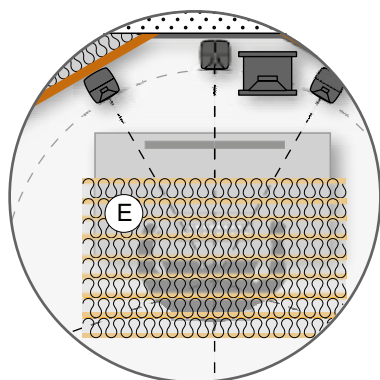
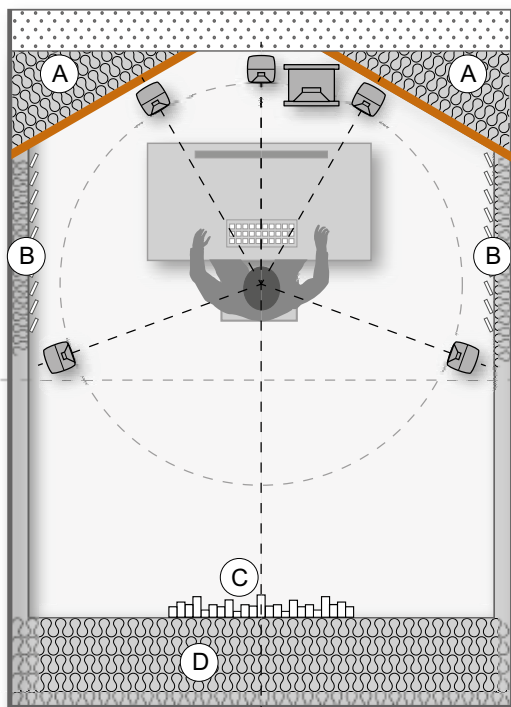

A

Cut the room front corners at 30 degree angle using high-mass materials (concrete, bricks, multi layered gypsum board, etc). In case building materials have medium mass, be sure to fill the empty space behind these walls with mineral wool.

B

Use a combination of absorption and diffusion on the side wall surfaces. Note that thin layers of porous absorbers only reduce HF reflections.

C

If the room is large enough, use diffusive and absorbing element(s) on the back wall.

D

Control low frequency room resonances using a large amount of absorption material for example in the back of the room and in the ceiling. Carefully designed and located panel resonator absorbers can also be used.

E

Use a combination of absorption and diffusion above the listening area to reduce acoustic reflections from the ceiling.

Listening distance and Sound Pressure Level

The distance between you and your monitors is crucial, both in terms of performance and the SPL delivered to the listening position. Use the table here to compare the SPL capabilities of Genelec monitors.

	0.5	1	1.5	2	3	5	10	15 (m)	
SAM Monitor Models	8320A	106 100	101 95	98 92	96 90	95 89	93 87	92 86	65 m³ 2'300 ft³ 0.22 s
	8330A	110 102	105 97	102 94	100 92	98 90	97 89	96 88	75 m³ 2'650 ft³ 0.23 s
	8340A	111 101	108 98	106 96	104 94	102 92	101 91	85 m³ 3'000 ft³ 0.24 s	
	8350A	113 104	110 101	108 99	106 96	104 95	103 94	95 m³ 3'350 ft³ 0.25 s	
	8331A	110 105	105 97	102 94	100 92	98 90	96 88	95 m³ 3'350 ft³ 0.25 s	
	8341A	116 107	111 102	108 99	106 97	104 95	102 93	101 92	85 m³ 3'000 ft³ 0.24 s
	8351B	119 109	114 104	110 100	108 98	106 96	104 94	103 93	95 m³ 3'350 ft³ 0.25 s
	8361A	124 115	118 109	115 106	113 104	111 102	108 99	107 98	110 m³ 3'900 ft³ 0.26 s
	1032C	115 105	111 101	110 100	110 100	107 97	105 95	104 94	110 m³ 3'900 ft³ 0.26 s
	S360A	118 112	115 109	113 107	110 104	108 102	106 100	106 100	125 m³ 4'420 ft³ 0.27 s
	1237A		115 109	113 107	110 104	108 102	106 100	106 100	125 m³ 4'420 ft³ 0.27 s
	1238CF /DF			112 102	109 99	107 97	105 95	105 95	120 m³ 4'250 ft³ 0.26 s
	1238A/AC			116 111	113 108	110 105	108 103	108 103	170 m³ 6'000 ft³ 0.29 s
	1234A/AC			120 115	117 112	113 108	111 106	110 105	200 m³ 7'100 ft³ 0.31 s
	1235A			124 119	121 116	118 113	114 109	113 108	400 m³ 14'200 ft³ 0.43 s
1236A			124 119	121 116	118 113	114 109	113 108	400 m³ 14'200 ft³ 0.43 s	

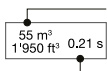

Room volume

Room reverberation time (RT60)

Short-term sound pressure levels

Maximum short-term sine wave sound pressure level averaged from 100 Hz to 3 kHz, measured in half-space, on-axis. Peak levels are higher. This number tends to under-estimate headroom by 4 dB, based on typical immersive standards and audio content. For more detailed information, please contact Genelec.



Long-term sound pressure levels

Maximum long-term RMS sound pressure level, measured in half-space, on-axis, with simulated programme signal according to IEC 60268-5 (limited by driver unit protection circuit).



Listening Distances and SPL

The short-term and long-term sound pressure levels (SPL) listed take into consideration the typical room volume and reverberation time for each monitor (right margin, based on ITU-R BS.1116). If the reverberation time is longer, it will mainly affect the long-term SPL that will be higher than shown.



Not Recommended Distances

When the distance to the monitor is too short, summing of sound from multiple drivers is not happening as designed.

Direct Sound Dominance

The balance between direct and reverberant sound has a profound influence on how your mixes will sound. The table shown will help you identify the optimum range of listening distances for the Genelec range.

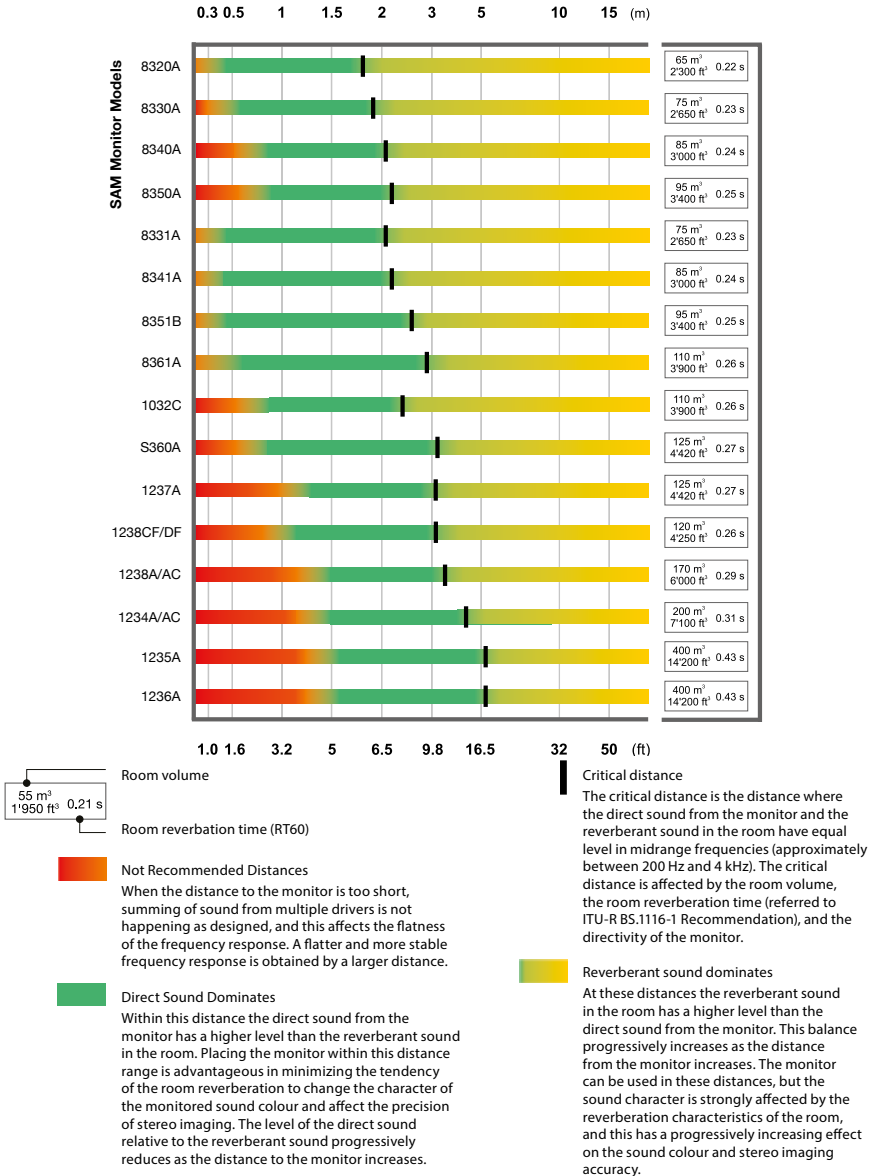

Product performance

Monitors	-6 dB LF Extension	Maximum SPL at 1 m ⁽¹⁾	Room volume up to	Subwoofers for 2 channels	Subwoofers for >5-channel Immersive
8010	67 Hz	96 dB	55 m ³	7040	7050
8020 / 8320	56 / 55 Hz	100 dB	65 m ³	7050 / 7350	7350
8030 / 8330	50 / 45 Hz	104 dB	75 m ³	7050 / 7350	7360
8040 / 8340	41 / 38 Hz	105 / 110 dB	85 m ³	7360 / 7370	7370
8050 / 8350	32 / 33 Hz	110 / 112 dB	95 m ³	7370	7380
8331	45 Hz	104 dB	75 m ³	7360	7370
8341	38 Hz	110 dB	85 m ³	7370	7370
8351	32 Hz	113 dB	95 m ³	7370	7380
8361	30 Hz	118 dB	110 m ³	7380	2x 7380
1032	33 Hz	114 dB	110 m ³	1-2 x 7380 ⁽²⁾	2-3 x 7380 ⁽²⁾
5360	36 Hz	118 dB	125 m ³	2 x 7380 ⁽²⁾	3 x 7380 or 1 x 7382 ⁽²⁾
1237	32 Hz	118 dB	125 m ³	2 x 7380 ⁽²⁾	3 x 7380 or 1 x 7382 ⁽²⁾
1238DF	50 Hz	117 dB	120 m ³	2 x 7380 ⁽²⁾	3 x 7380 or 1 x 7382 ⁽²⁾
1238 / AC	30 Hz	121 dB	170 m ³	3 x 7380 or 1 x 7382 ⁽²⁾	1-2 x 7382 ⁽²⁾
1234 / AC	29 Hz	125 dB	200 m ³	7382 ⁽²⁾	2 x 7382 ⁽²⁾
1236	17 Hz	130 dB	400 m ³	2 x 7382 ⁽²⁾	2-3 x 7382 ⁽²⁾

(1) Maximum short term sine wave acoustic output on axis in half space, averaged from 100 Hz to 3 kHz at 1 m distance.

(2) Additional subwoofers of the same type may be required in a larger room with bass heavy program material.

(3) Subwoofers are not necessarily required for a 1236 installation as these monitors are already full range. For immersive systems, subwoofers can be used to reproduce the LFE channel.

Subwoofers	-6 dB LF extension	Maximum SPL at 1 m*	Room volume up to
7040	30 Hz	100 dB	65 m ³
7050	24 Hz	103 dB	75 m ³
7350	22 Hz	104 dB	75 m ³
7360	19 Hz	109 dB	85 m ³
7370	19 Hz	113 dB	110 m ³
7380	16 Hz	119 dB	130 m ³
7382	15 Hz	129 dB	400 m ³

* Maximum short-term sine wave acoustic output on axis in half space, averaged from 30 Hz to 85 Hz at 1 m distance.

Sound basics

Sound travels approximately 344 m/s (1130 ft/s). It takes 3 ms for sound to travel 1 meter (3,3 ft).

In free-field conditions (no walls, floor, or ceiling) the sound volume drops 6 dB when the distance doubles.

1 m	100 dB	0 dB
2 m	94 dB	-6 dB
4 m	88 dB	-12 dB

Sound level increases by 3 dB when the amplifier power doubles.

100 W	85 dB	0 dB
200 W	88 dB	+3 dB
400 W	91 dB	+6 dB

The industry standard reference sound pressure level (SPL) for cinema and TV sound production work is between 82 and 85 dB at the listening position.

Frequency spectrum

The audible frequency spectrum covers 10 octaves (up to 40 Hz, 80, 160, 320, 640, 1'280, 2'560, 5'120, 10'240, 20'480 Hz) which can conveniently divide the spectrum as follows.

Subsonic bass frequencies	below 16 Hz	Not audible for humans.
Very low frequencies	16 Hz – 40 Hz	Lowest audible octave for humans.
	40 Hz – 80 Hz	Music low frequencies, kick drums, bass instruments
Low frequencies	80 Hz – 160 Hz	Low register of a grand piano.
	160 Hz – 320 Hz	Middle C of a piano.
Midrange frequencies	320 Hz – 1'280 Hz	Music midrange frequencies
Upper midrange frequencies	1'280 Hz – 2'560 Hz	Low-order harmonics of most instruments.
	2'560 Hz – 5'120 Hz	The ear is the most sensitive in this range.
High frequencies	5'120 Hz – 10'240 Hz	Brightness and harmonics
Extremely high frequencies	10'240 Hz – 20'480 Hz	Highest harmonics. Inaudible to humans above 20 kHz

Sound radiation

At low frequencies, typically below 200 Hz, monitors radiate omnidirectionally. This means that the same sound pressure is created in any direction around the monitor. At higher frequencies, the radiation becomes directional: midrange frequencies radiate in a hemispherical pattern and very high frequencies can radiate in a beam- or ray-like pattern. Genelec designs monitors with controlled directivity and this minimizes the changes in the directivity across frequencies.

Soundwave propagation in various frequency ranges

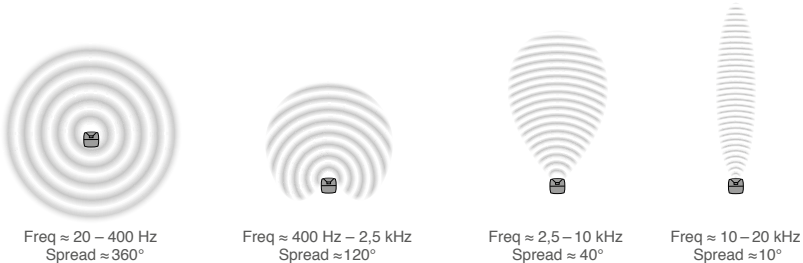

Radiation space

The radiation space is the volume into which a monitor is radiating sound. The sound level increases when the sound radiation is limited by walls. Every halving of the radiation space by a wall close to the monitor doubles the sound pressure level.

A monitor with a flat frequency response in free space produces up to 6 dB higher sound level against a solid wall. In a corner (two walls) this gain can be 12 dB. With three boundaries (corner close to ceiling) the gain can be +18 dB. This can be particularly seen at low frequencies.

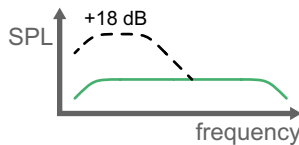
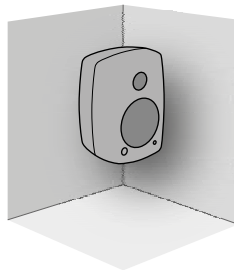
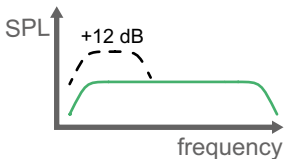
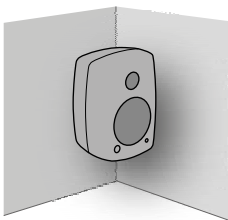
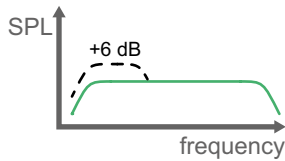
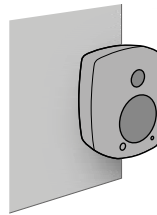
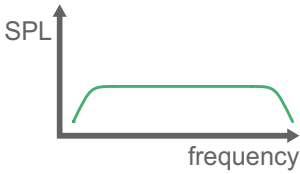
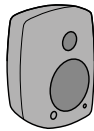

Cancellation because of a wall behind the monitor

When there is some distance between the monitor and the wall, at the frequency where this distance is equal to one quarter of the sound wavelength, the wall reflection is out of phase with the monitor, and the reflected audio cancels the audio from the monitor. At this frequency, the sound level is reduced. How much reduction occurs depends on the distance and on how much sound the wall reflects.

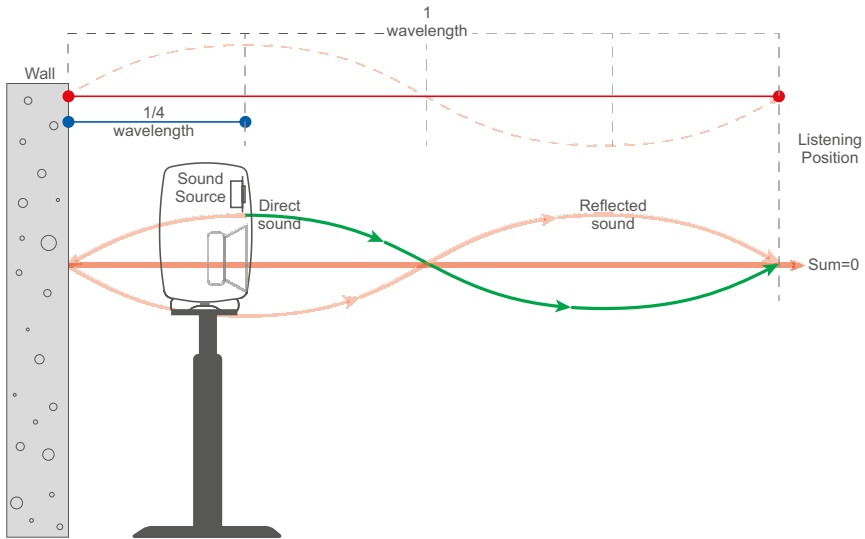

Wall reflections generate a set of cancellations at different frequencies (this is also called comb filtering). The first cancellation notch can be between 6 dB and 20 dB deep. Equalization of the monitor output level does not help, as the same level change applies also to the reflected sound.

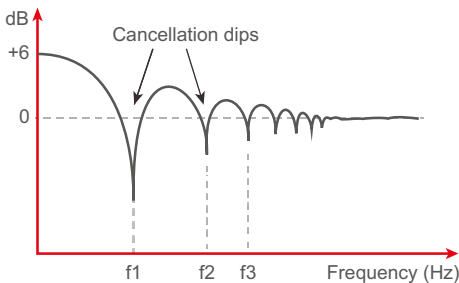

A first solution is to flush mount the monitors in a hard wall (creating a very large baffle) eliminating the rear wall reflections and therefore cancellations.

Another possibility is to place the monitor very close to the wall. This raises the lowest cancellation frequency so high that the monitor has become forward-directing, and the cancellation no longer occurs. Remember that the low frequency boost should be compensated for when the monitor is mounted close to the wall (up to +6 dB gain).

Alternatively, one could move the monitor considerably far away from the wall: the cancellation frequency moves below the low frequency cut-off of the monitor. When the monitor moves away from the walls, it also moves close to the listener. This increases the direct sound level and reduces the reflected sound level, and this also improves sound quality.

A different solution is to modify the wall and make it very absorptive so that the amplitude of the reflected energy is small and does not cancel the direct sound.

When a subwoofer is used to reproduce low frequencies the monitors can be placed more freely. The subwoofer should be placed close to the wall(s). The monitors may be placed at distances where low frequency notches do not occur in their pass-band.

Genelec G • Stencil tool

How to draw correct monitor angles with the G • Stencil?

Use an architectural plan of your room. Place the centre of the G • Stencil on the plan in the selected listening position on an even surface. Attach a pin to the centre of the stencil to hold it. Draw the reference centreline along the room symmetry axis. Then draw all other lines at the appropriate angles corresponding to your monitoring setup.

<http://www.youtube.com/watch?v=ZDGhPvpfmoY>

The G • Stencil is available at the Genelec Webshop. Order code MAI-0132.

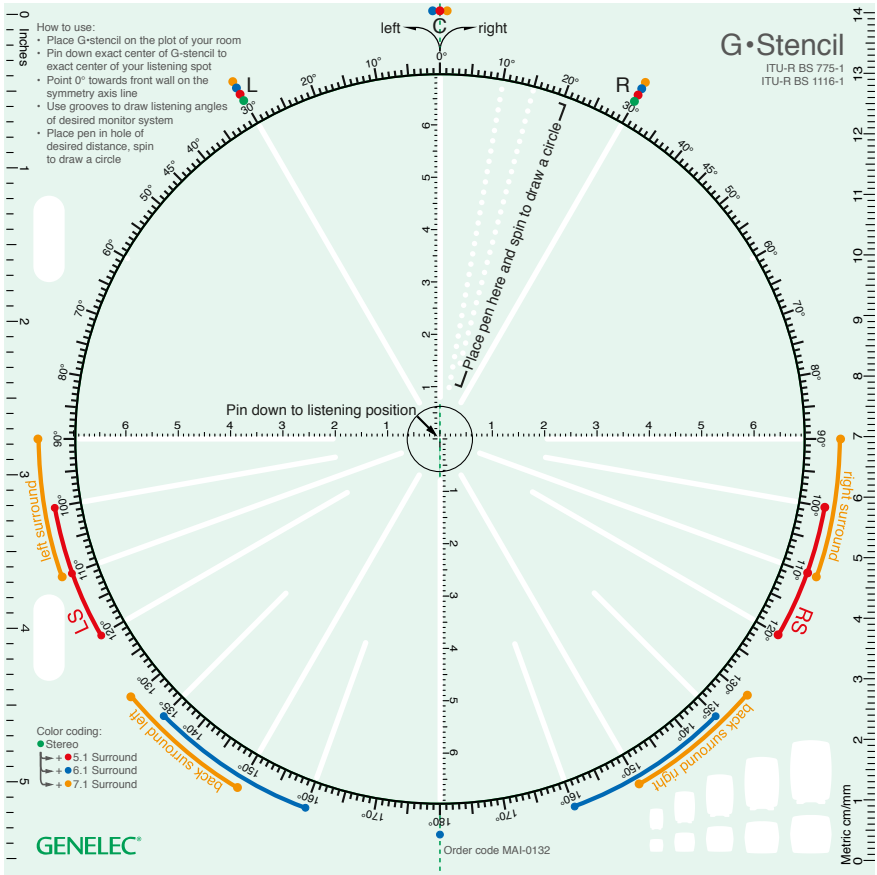

Test signals

Various useful test signals can be downloaded from the Genelec website.

GENELEC®

Genelec OY
Olvitie 5
FI-74100 Iisalmi
Finland

T +358 17 83 881

genelec@genelec.com
www.genelec.com